



POWYS TEACHING HEALTH BOARD JOB DESCRIPTION

<u>JOB DETAILS</u>	
Job Title:	Health Care Support Worker - Nurse Training
Pay Band:	Band 2
Hours of Work and Nature of Contract:	To be completed on recruitment
Service Group:	Nursing Services
Department:	To be completed on recruitment
Base:	To be completed on recruitment
<u>ORGANISATIONAL ARRANGEMENTS</u>	
Managerially Accountable to:	Nurse
Professionally Accountable to:	Director of Nursing
<u>VALUES & BEHAVIOUR</u>	
	<p>Our Values and Behaviours are demonstrated through our 'Health Care Strategy' centred on the Needs of the Individual' through Respect, Trust, Integrity, Working Together, Kindness and Caring and Fairness and Equality.</p>

Important Note:

This is recruitment specifically for part-time Nurse Training roles in conjunction with the Open University

JOB SUMMARY / PURPOSE:

The post holder will work under the supervision/guidance of a Registered Nurse/Clinical Lead.

DUTIES & RESPONSIBILITIES

- To assist nursing staff and the multi-disciplinary team (MDT) in the assessment process by contributing to developing a picture of patients' needs.
- To assist in the delivery of care as identified in the patient's care plan. At all times reporting observations on progress or deterioration to the Nurse in Charge.
- To undertake care in accordance with the standards of care set out in the Fundamentals of Care.
- To develop skills and experience at carrying out delegated duties in respect of the physical and psychological needs of the patient under the supervision of the Registered Nurse in charge.
- To respect the patient/carers and representatives, being sensitive at all times to their views and wishes.
- To maintain a safe environment for the patient.
- To assist patients where necessary, with all aspects of personal hygiene.
- To maintain the dignity of the patient at all times and provide the maximum amount of privacy.
- To respect confidential information obtained in the course of one's duties, always referring to the Nurse in Charge who will facilitate necessary information sharing.

PROFESSIONAL DEVELOPMENT & SUPERVISION

- To identify a personal development plan incorporating measures both through training and self-directed study/experiences.
- Complete essential training requirements.
- To work in accordance with Powys Local Health Board policy and procedures in all aspects of practice and delegated duties.

- To assist with the support of new team members.
- Contribute to all clinical governance activity.
- Work as a member of the MDT.
- Contribute to a positive clinical environment in which people feel valued and motivated.
- To be responsible for communicating effectively both verbally and in writing with other members of the MDT.
- To develop a plan to address and build on essential skills and participate in an ongoing education process where applicable.
- To actively contribute to the maintenance of standards by informing the clinical lead/nominated deputy, of any deficiencies which may affect the maintenance of standards (including safety) of staff or patients.
- To work at all times within the boundaries of the delegated duties, at no time undertaking procedures/interventions that have not been agreed by the clinical lead/nominated deputy.
- Escort duties will be required as deemed appropriate by the clinical lead/nominated deputy.
- Contribute to reporting arrangements e.g. complaints, incident reporting.
- Be prepared to work flexibly in undertaking other duties as required, both within and outside of the designated service area.

PERSONAL SPECIFICATION			
ATTRIBUTES	ESSENTIAL	DESIRABLE	METHOD OF ASSESSMENT
Qualifications and/or Knowledge	<p>GCSE A, B or C in English (or Welsh) or the equivalent qualification</p> <p>GCSE A, B or C in Maths or the equivalent qualification</p> <p>Can demonstrate clear transferable skills valid to the health care setting equivalent to NVQ / QCF level 2</p> <p>NVQ / QCF level 2 in Health Care or equivalent</p>	<p>ECDL</p> <p>Formal qualification (not necessarily in health care setting)</p>	<p>Application Form & pre-employment checks</p>
Experience	<p>Clear communication skills, oral and written</p> <p>Identify patients' progress in evaluating nursing care</p> <p>Participation in meetings</p> <p>Team participation in monitoring, auditing and evaluating the basics of care</p>	<p>Ability to speak Welsh</p>	<p>Application Form & Interview</p>
Aptitude and Abilities	<p>Be able to put a caring attitude into words</p> <p>Be able to undertake simple observations and chart them accurately:</p> <ul style="list-style-type: none"> • temperature • Heartbeat • breath • Blood pressure • Blood glucose monitoring • Monitoring fluid input/output • Bowel voids • Dietary feed <p>Ability to undertake ECG test recording</p> <p>Ability to take patient samples:</p> <ul style="list-style-type: none"> • Urine • Faeces • blood • MRSA Swabs 		<p>Interview</p>

ATTRIBUTES	ESSENTIAL	DESIRABLE	METHOD OF ASSESSMENT
Values	Can demonstrate PTHB Values		Application Form & Interview
Other	<p>Ability to undertake work during unsocial hours</p> <p>Can demonstrate an understanding of Health and Safety issues</p> <p>Ability to travel</p> <p>Ability to recognise and discuss dual role of employee and student</p>		Application Form & Interview

GENERAL REQUIREMENTS

Include those relevant to the post requirements

- **Values:** All employees of the Health Board are required to demonstrate and embed the Values and Behaviour Statements in order for them to become an integral part of the post holder's working life and to embed the principles into the culture of the organisation.
- **Registered Health Professional:** All employees who are required to register with a professional body, to enable them to practice within their profession, are required to comply with their code of conduct and requirements of their professional registration.
- **Healthcare Support Workers:** Healthcare Support Workers make a valuable and important contribution to the delivery of high-quality healthcare. The national Code of Conduct for NHS Wales describes the standards of conduct, behaviour and attitude required of all Healthcare Support Workers employed within NHS Wales. Health Care Support Workers are responsible, and have a duty of care, to ensure their conduct does not fall below the standards detailed in the Code and that no act or omission on their part harms the safety and wellbeing of service users and the public, whilst in their care.
- **Competence:** At no time should the post holder work outside their defined level of competence. If there are concerns regarding this, the post holder should immediately discuss them with their Manager/Supervisor. Employees have a responsibility to inform their Manager/Supervisor if they doubt their own competence to perform a duty.
- **Learning and Development:** All staff must undertake induction/orientation programmes at Corporate and Departmental level and must ensure that any statutory/mandatory training requirements are current and up to date. Where considered appropriate, staff are required to demonstrate evidence of continuing professional development.
- **Performance Appraisal:** We are committed to developing our staff and you are responsible for participating in an Annual Performance Development Review of the post.
- **Health & Safety:** All employees of the organisation have a statutory duty of care for their own personal safety and that of others who may be affected by their acts or omissions. The post holder is required to co-operate with management to enable the organisation to meet its own legal duties and to report any hazardous situations or defective equipment. The post holder must adhere to the organisation's Risk Management, Health and Safety and associate policies.
- **Risk Management:** It is a standard element of the role and responsibility of all staff of the organisation that they fulfil a proactive role towards the management of risk in all of their actions. This entails the risk assessment of all situations, the taking of appropriate actions and reporting of all incidents, near misses and hazards.
- **Welsh Language:** All employees must perform their duties in strict compliance with the requirements of their organization's Welsh Language Scheme and take

every opportunity to promote the Welsh language in their dealings with the public.

- **Information Governance:** The post holder must at all times be aware of the importance of maintaining confidentiality and security of information gained during the course of their duties. This will in many cases include access to personal information relating to service users.
- **Data Protection:** The post holder must treat all information, whether corporate, staff or patient information, in a discreet and confidential manner in accordance with the provisions of the General Data Protection Legislation and Organisational Policy. Any breach of such confidentiality is considered a serious disciplinary offence, which is liable to dismissal and / or prosecution under current statutory legislation and the HB or Trust Disciplinary Policy.
- **Records Management:** As an employee of this organisation, the post holder is legally responsible for all records that they gather, create or use as part of their work within the organisation (including patient health, staff health or injury, financial, personal and administrative), whether paper based or on computer. All such records are considered public records and the post holder has a legal duty of confidence to service users (even after an employee has left the organisation). The post holder should consult their manager if they have any doubt as to the correct management of records with which they work.
- **Equality and Human Rights:** The Public Sector Equality Duty in Wales places a positive duty on the HB/Trust to promote equality for people with protected characteristics, both as an employer and as a provider of public services. There are nine protected characteristics: age; disability; gender reassignment; marriage and civil partnership; pregnancy and maternity; race; religion or belief; sex and sexual orientation. The HB/Trust is committed to ensuring that no job applicant or employee receives less favourable treatment on any of the above grounds. To this end, the organisation has an Equality Policy and it is for each employee to contribute to its success.
- **Dignity at Work:** The organisation condemns all forms of bullying and harassment and is actively seeking to promote a workplace where employees are treated fairly and with dignity and respect. All staff are requested to report any form of bullying and harassment to their Line Manager or to any Director of the organisation. Any inappropriate behaviour inside the workplace will not be tolerated and will be treated as a serious matter under the HB/Trust Disciplinary Policy.
- **DBS Disclosure Check:** In this role you will have **direct contact** with patients / service users / children /vulnerable adults in the course of your normal duties. You will therefore be required to apply for a Criminal Record Bureau Enhance Disclosure Check as part of the HB/Trust's pre-employment check procedure.
- **Safeguarding Children and Adults at Risk:** Powys Teaching Health Board is fully committed to safeguarding people. Employees and workers (including agency and bank workers) are responsible for ensuring they understand what actions to take if they have reasonable cause to suspect that a child or an adult is at risk of harm and mandatory safeguarding training is completed in line with their role specific competencies.

- **Infection Control:** The organisation is committed to meet its obligations to minimise infections. All staff are responsible for protecting and safeguarding patients, service users, visitors and employees against the risk of acquiring healthcare associated infections. This responsibility includes being aware of the content of and consistently observing Health Board/Trust Infection Prevention & Control Policies and Procedures.
- **No Smoking:** To give all patients, visitors and staff the best chance to be healthy, all Health Board/Trust sites, including buildings and grounds, are smoke free.
- **Flexibility Statement:** The duties of the post are outlined in this Job Description and Person Specification and may be changed by mutual agreement from time to time.

Organisational Chart

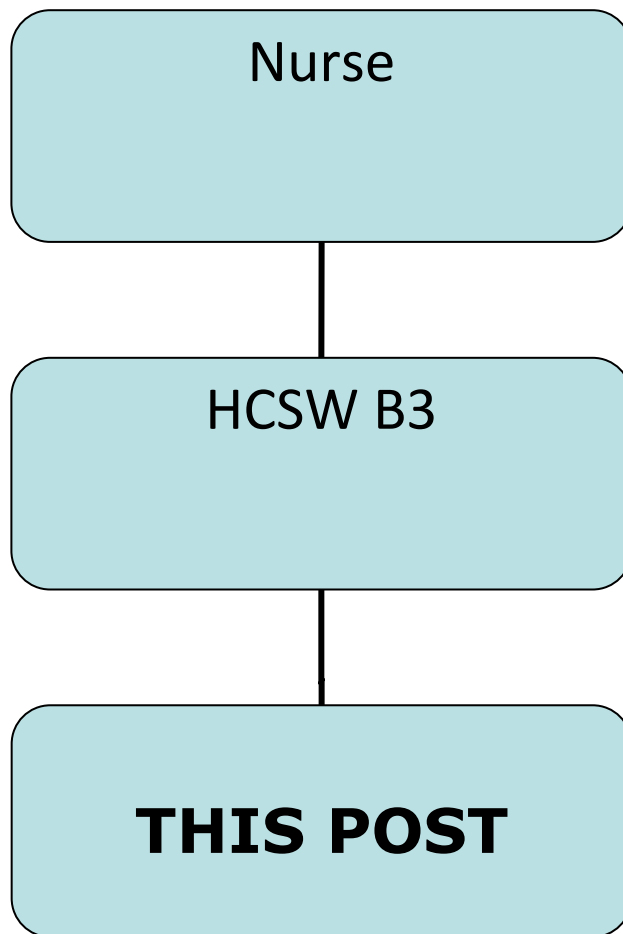

BWRDD IECHYD ADDYSGU POWYS SWYDD-DDISGRIFIAD

<u>MANYLION Y SWYDD:</u>	
Teitl Swydd:	Gweithiwr Cymorth Gofal Iechyd
Band cyflog:	2
Oriau Gwaith a Natur y Contract:	I'w gwblhau ar ôl recriwtio
Is-adran/Cyfarwyddiaeth:	I'w chadarnhau
Adran:	Gwasanaethau Nyrso
Safle:	Cyfleoedd amrywiol ar gael
<u>TREFNIADAU SEFYDLIADOL:</u>	
Yn Rheolaethol Atebol i:	
Yn Broffesiynol Atebol i:	
<u>VALUES & BEHAVIOUR</u>	
	<p>Mae ein 'Strategaeth Gofal Iechyd', sy'n canolbwyntio ar Anghenion yr Unigolyn, sef Parch, Ymddiriedaeth, Gonestrwydd, Cydweithio, Caredig a Gofalgar a Thegwch a Chydraddoldeb, yn dangos ein Gwerthoedd a'n Hymddygiadau.</p>

Nodyn Pwysig:

Dyma recriwtio'n benodol ar gyfer rolau Hyfforddi Nyrsys rhan-amser ar y cyd â'r Brifysgol Agored

CRYNODEB SWYDD / DIBEN:

Bydd deiliad y swydd yn gweithio o dan oruchwyliaeth/arweiniad Nyrs Gofrestredig/Clinical Lead.

DYLETSWYDDAU A CHYFRIFOLDEBAU :

Rheoli Gofal

- Cynorthwyo staff nyrsio a'r tîm amlddisgyblaeth yn y broses asesu trwy gyfrannu at ddatblygu llun o anghenion cleifion.
- Cynorthwyo i ddarparu gofal yn unol â'r hyn a nodir yng nghynllun gofal y claf. Bob amser, rhoi gwybod i'r nyrs gyfrifol am yr hyn a welir o ran cynnydd neu ddirywiad.
- Ymgymryd â gofal yn unol â'r safonau gofal y manylir arnyn nhw yn yr Hanfodion Gofal.
- Datblygu sgiliau a phrofiad o gyflawni dyletswyddau sydd wedi'u dirprwyo o ran anghenion corfforol a seicolegol y claf, dan oruchwyliaeth y nyrs gofrestredig gyfrifol.
- Parchu'r claf/gofalwyr a chynrychiolwyr, gan fod yn sensitif bob amser i'w barn a'u dymuniadau.
- Cynnal amgylchedd diogel i'r claf.
- Cynorthwyo cleifion â phob agwedd ar hylendid personol, lle bo angen hynny.
- Cynnal urddas y claf bob amser a sicrhau ei fod/ei bod yn cael cymaint o breifatrwydd â phosibl.
- Parchu gwybodaeth gyfrinachol a gesglir wrth gyflawni ei (d)dyletswyddau, gan gyfeirio at y nyrs gyfrifol bob amser, a fydd yn hwyluso rhannu gwybodaeth angenrheidiol.

Datblygiad Proffesiynol a Goruchwyliaeth

- Nodi cynllun datblygu personol, yn cynnwys mesurau trwy hyfforddiant a hefyd trwy astudiaeth/profiadau hunangyfeiriedig.

- Cwblhau gofynion hyfforddi hanfodol.
- Ymgymryd â hyfforddiant NVQ fel rhan o gynlluniau datblygu personol.
- Gweithio yn unol â pholisi a gweithdrefnau Bwrdd Iechyd Lleol Powys ym mhob agwedd ar arfer a dyletswyddau sydd wedi'u dirprwyo.
- Cynorthwyo â chefnogi aelodau newydd o'r tîm.
- Mynd ati i gymryd rhan mewn hyfforddiant arfarnu.
- Cyfrannu at bob gweithgaredd llywodraethu clinigol.
- Gweithio fel aelod o'r tîm amlddisgyblaeth.
- Cymryd rhan mewn cyfarfodydd tîm a phrosiectau datblygu.
- Cyfrannu at amgylchedd clinigol positif lle y mae pobl yn teimlo'n llawn cymhelliant ac yn teimlo bod eraill yn eu gwerthfawrogi.
- Bod yn gyfrifol am gyfathrebu'n effeithiol, boed ar lafar neu'n ysgrifenedig, ag aelodau eraill o'r tîm amlddisgyblaeth.
- Datblygu cynllun datblygu personol gyda'i r(h)eolwr llinell sy'n adeiladu ar set o sgiliau sydd wedi'u hen sefydlu.
- Cymryd rhan mewn proses addysg barhaus.
- Mynd ati i gyfrannu at gynnal safonau trwy roi gwybod i'r arweinydd clinigol / dirprwy enwebedig am unrhyw ddiffygion a allai effeithio ar gynnal safonau (gan gynnwys diogelwch) staff neu gleifion.
- Gweithio bob amser o fewn ffiniau'r dyletswyddau sydd wedi'u dirprwyo, a pheidio byth â gwneud gweithdrefnau/ymyriadau nad ydy'r arweinydd clinigol / dirprwy enwebedig wedi cytuno arnyn nhw.
- Bydd angen gwneud dyletswyddau cydymaith y mae'r arweinydd clinigol / dirprwy enwebedig yn eu hystyried yn briodol.
- Cyfrannu at drefniadau adrodd e.e. adrodd ar gwynion, digwyddiadau.
- Bod yn barod i weithio'n hyblyg wrth gyflawni dyletswyddau eraill yn ôl y galw, boed o fewn neu'r tu allan i'r maes gwasanaeth dynodedig.

MANYLEB PERSON			
RHINWEDDAU	HANFODOL	DYMUNOL	DULL ASESU
Cymwysterau a / neu Wybodaeth	<p>TGAU A, B neu C mewn Cymraeg (neu Saesneg) neu'r cymhwyster cyfatebol</p> <p>TGAU A, B neu C mewn Mathemateg neu'r cymhwyster cyfatebol</p> <p>Yn gallu dangos sgiliau trosglwyddadwy clir sy'n ddilys i'r lleoliad gofal iechyd sy'n cyfateb i NVQ / FfCCh lefel 2</p> <p>NVQ / FfCCh lefel 2 mewn Gofal Iechyd neu gyfwerth</p>	<p>ECDL</p> <p>Cymhwyster ffurfiol (nid o reidrwydd ym maes gofal iechyd)</p>	Ffurflen gais a gwiriad au cyn cyflogi
Profiad	<p>Sgiliau cyfathrebu clir, llafar ac ysgrifenedig</p> <p>Nodi cynnydd cleifion o ran gwerthuso gofal nyrso</p> <p>Cymryd rhan mewn cyfarfodydd</p> <p>Cyfranogiad tîm mewn monitro, archwilio a gwerthuso hanfodion gofal</p>		Cyfweliad
Doniau a Galluoedd	<p>Gallu rhoi agwedd ofalgar mewn geiriau</p> <p>Gallu ymgymryd ag arsylwadau syml a'u siartio'n gywir:</p> <ul style="list-style-type: none"> • tymheredd • Curiad calon • anadl • Pwysedd gwaed • Monitro glwcos gwaed • Monitro mewnbwn/allbwn hylif • Bylchau yn y coluddyn • Porthiant deietegol <p>Y gallu i ymgymryd â chofnodi profion ECG</p> <p>Y gallu i gymryd samplau cleifion:</p> <ul style="list-style-type: none"> • troeth • Ysgarthion • gwaed • Swabiau MRSA 	Gallu siarad Cymraeg	Ffurflen Gais Cyfweliad Geirdaon

RHINWEDDAU	HANFODOL	DYMUNOL	DULL ASESU
Gwerthoedd	Gallu dangos Gwerthoedd PTHB	Gallu rheoli sefyllfaoedd sy'n ingol ichi	Ffurflen gais a chyfweli ad
Arall	<p>Y gallu i ymgymryd â gwaith yn ystod oriau anghymdeithasol</p> <p>Gallu dangos dealltwriaeth o faterion Iechyd a Diogelwch</p> <p>Y gallu i deithio</p> <p>Y gallu i adnabod a thrafod rôl ddeuol y cyflogai a'r myfyriwr</p>		

GOFYNION CYFFREDINOL

Yn cynnwys y rheini sy'n berthnasol i ofynion y swydd

- **Gwerthoedd:** Mae gofyn i bob un o gyflogeion y Bwrdd Iechyd ddangos a gwreiddio'r Datganiadau Gwerthoedd ac Ymddygiad er mwyn iddyn nhw ddod yn rhan annatod o fywyd gweithio deiliad y swydd, a gwreiddio'r egwyddorion yn niwylliant y sefydliad.
- **Gweithwyr Iechyd Proffesiynol Cofrestredig:** Mae gofyn i bob cyflogai sydd angen cofrestru â chorff proffesiynol, i'w galluogi i arfer o fewn eu proffesiwn, gydymffurfio â'u cod ymddygiad a gofynion eu cofrestriad proffesiynol.
- **Gweithwyr Cymorth Gofal Iechyd:** Mae Gweithwyr Cymorth Gofal Iechyd yn gwneud cyfraniad gwerthfawr a phwysig i'r ffordd o gyflenwi gofal iechyd o ansawdd uchel. Mae'r Cod Ymddygiad cenedlaethol ar gyfer GIG Cymru'n disgrifio'r safonau ymddygiad ac ymagwedd y mae gofyn i bob Gweithiwr Cymorth Gofal Iechyd a gyflogir yn GIG Cymru eu cyrraedd. Mae Gweithwyr Cymorth Gofal Iechyd yn gyfrifol am sicrhau nad yw eu hymddygiad yn methu â chyrraedd y safonau y manylir arnyn nhw yn y Cod, ac nad yw unrhyw beth y maen nhw'n ei wneud, neu ddim yn ei wneud, yn gwneud drwg i ddiogelwch a llesiant defnyddwyr gwasanaeth a'r cyhoedd, tra'u bod yn eu gofal.
- **Cymhwysedd:** Ni ddylai deiliad y swydd fyth weithio y tu allan i'w lefel cymhwysedd ddiffiniedig. Os oes yna bryderon ynglŷn â hyn, dylai deiliad y swydd eu trafod ar unwaith â'i Reolwr/Goruchwyliwr. Mae gan gyflogeion gyfrifoldeb i roi gwybod i'w Rheolwr/Goruchwyliwr os ydyn nhw'n amau eu cymhwysedd eu hunain i berfformio dyletswydd.
- **Dysgu a Datblygu:** Mae'n rhaid i bob aelod o staff ddilyn rhaglenni cynefino/ymgyfarwyddo ar lefel Gorfforaethol ac Aadrannol, ac mae'n rhaid iddyn nhw sicrhau bod unrhyw ofynion hyfforddiant statudol/gorfodol yn gyfoes ac wedi'u diweddarau. Mae gofyn i staff ddangos tystiolaeth o ddatblygiad proffesiynol parhaus lle yr ystyrir hyn yn briodol.
- **Arfarnu Perfformiad:** Rydyn ni wedi ymrwymo i ddatblygu ein staff ac rydych chi'n gyfrifol am gymryd rhan mewn Adolygiad Blynyddol o Ddatblygu Perfformiad yn y swydd.
- **Iechyd a Diogelwch:** Mae gan bob un o gyflogeion y sefydliad ddyletswydd statudol i ofalu am eu diogelwch personol eu hunain a diogelwch eraill y gallai y pethau y maen nhw'n eu gwneud, neu ddim yn eu gwneud, effeithio arnyn nhw. Mae gofyn i ddeiliad y swydd gydweithredu â rheolwyr i alluogi'r sefydliad i gyflawni ei ddyletswyddau cyfreithiol ei hun, a rhoi gwybod am unrhyw sefyllfaoedd peryglus neu offer diffygiol. Rhaid i ddeiliad y swydd lynu at bolisi Rheoli Risg, Iechyd a Diogelwch y sefydliad, a pholisïau cysylltiedig.
- **Rheoli Risg:** Mae'n un o elfennau safonol rôl a chyfrifoldeb pob aelod o staff y sefydliad eu bod nhw'n cyflawni rôl ragweithiol o ran rheoli risg ym mhopeth y maen nhw'n ei wneud. Mae hyn yn golygu gwneud asesiad risg o bob sefyllfa, cymryd camau priodol ac adrodd am bob cythrwfl, perygl, a chythrwfl a fu bron â digwydd.

- **Yr Iaith Gymraeg:** Rhaid i bob cyflogai berfformio'i ddyletswyddau gan gydymffurfio'n llwyr â gofynion Cynllun Iaith Gymraeg eu sefydliad, a manteisio ar bob cyfle i hybu'r Gymraeg wrth ddelio â'r cyhoedd.
- **Llywodraethu Gwybodaeth:** Rhaid i ddeiliad y swydd fod yn ymwybodol bob amser o bwysigrwydd cynnal cyfrinachedd a chadw'n ddiogel unrhyw wybodaeth sy'n dod i'w ran wrth wneud ei ddyletswyddau. Bydd hyn, mewn sawl achos, yn cynnwys mynediad at wybodaeth bersonol sy'n ymwneud â defnyddwyr gwasanaeth.
- **Diogelu Data:** Rhaid i ddeiliad y swydd drin yr holl wybodaeth, boed yn wybodaeth am y gorfforaeth, staff neu gleifion, mewn modd gochelgar a chyfrinachol yn unol â darpariaethau'r Ddeddfwriaeth Gyffredinol ar Ddiogelu Data a'r Polisi Sefydliadol. Ystyrir unrhyw achos o dorri cyfrinachedd o'r fath yn drosedd ddisgyblu ddifrifol a allai arwain at ddiswyddo a / neu erlyn dan ddeddfwriaeth statudol gyfredol a Pholisi Disgyblu'r Bwrdd neu'r Ymddiriedolaeth Iechyd.
- **Rheoli Cofnodion:** Fel cyflogai'r sefydliad hwn, mae deiliad y swydd yn gyfreithiol gyfrifol am bob cofnod y mae'n ei gasglu, ei greu neu ei ddefnyddio fel rhan o'i waith o fewn y sefydliad (gan gynnwys iechyd cleifion, iechyd neu anafiad staff, gwybodaeth ariannol, bersonol a gweinyddol), boed ar bapur neu ar gyfrifiadur. Ystyrir cofnodion o'r fath yn gofnodion cyhoeddus ac mae gan ddeiliad y swydd ddyletswydd cyfrinachedd gyfreithiol i ddefnyddwyr gwasanaeth (hyd yn oed ar ôl i gyflogai fod wedi gadael y sefydliad). Dylai deiliad y swydd ymgynghori â'i reolwr os oes unrhyw amheuaeth o gwbl ynglŷn â sut i reoli'n gywir y cofnodion y mae'n gweithio â nhw.
- **Cydraddoldeb a Hawliau Dynol:** Mae'r Ddyletswydd Cydraddoldeb yn y Sector Cyhoeddus yng Nghymru'n gosod dyletswydd bositif ar y Bwrdd Iechyd/Ymddiriedolaeth i hybu cydraddoldeb i bobl â nodweddion gwarchoddedig, fel cyflogwr a hefyd fel darparwr gwasanaethau cyhoeddus. Mae yna naw o nodweddion gwarchoddedig: oedran; anabled; ailbennu rhywedd; priodas a phartneriaeth sifil; beichiogrwydd a mamolaeth; hil; crefydd neu gredo; rhyw a chyfeiriadedd rhywiol. Mae'r Bwrdd Iechyd/Ymddiriedolaeth wedi ymrwymo i sicrhau nad yw unrhyw ymgeisydd am swydd neu gyflogai'n derbyn triniaeth lai ffafriol ar unrhyw sail a nodir uchod. I'r perwyl hwn, mae gan y sefydliad Bolisi Cydraddoldeb ac mae hi i fyny i bob cyflogai gyfrannu at ei lwyddiant.
- **Urddas yn y Gwaith:** Mae'r sefydliad yn condemnio pob ffurf ar fwlio ac aflonyddu ac mae'n mynd ati'n weithredol i geisio hybu gweithle lle mae cyflogaion yn cael eu trin yn deg a chydag urddas a pharch. Mae gofyn i bob aelod o staff roi gwybod am unrhyw ffurf ar fwlio ac aflonyddu i naill ai eu Rheolwr Llinell neu i unrhyw Gyfarwyddwr y sefydliad. Ni oddefir unrhyw ymddygiad amhriodol yn y gweithle a chaiff hyn ei drin fel mater difrifol dan Bolisi Disgyblu'r BI/Ymddiriedolaeth.
- **Gwiriad Datgelu DBS:** Yn y rôl hon fe fydd gennych chi **gyswllt uniongyrchol** â chleifion / defnyddwyr gwasanaeth / plant /oedolion agored i niwed wrth wneud eich dyletswyddau arferol. Felly fe fydd gofyn ichi ymgeisio am Wiriad Datgelu

Manylach y Swyddfa Cofnodion Troseddol fel rhan o weithdrefn wirio cyn cyflogi'r BI/Ymddiriedolaeth.

- **Diogelu Plant ac Oedolion mewn Risg:** Mae Bwrdd Iechyd Addysgu Powys wedi ymrwymo'n llwyr i ddiogelu pobl. Mae cyflogeion a gweithwyr (gan gynnwys gweithwyr asiantaeth a gweithwyr cronfa) yn gyfrifol am sicrhau eu bod nhw'n deall pa gamau i'w cymryd os oes ganddyn nhw achos rhesymol i amau bod plentyn neu oedolyn mewn risg o niwed, a'u bod nhw'n cwblhau hyfforddiant diogelu gorfodol yn unol â chymwyseddau penodol eu rôl.
- **Rheoli Haint:** Mae'r sefydliad wedi ymrwymo i ddiwallu ei rwymedigaethau i sicrhau cyn lleied o heintiau â phosibl. Mae pob aelod o staff yn gyfrifol am amddiffyn a diogelu cleifion, defnyddwyr gwasanaeth, ymwelwyr a chyflogeion rhag y risg o ddal heintiau sy'n gysylltiedig â gofal iechyd. Mae'r cyfrifoldeb hwn yn cynnwys bod yn ymwybodol o gynnwys Polisiâu a Gweithdrefnau Atal a Rheoli Haint y Bwrdd Iechyd/Ymddiriedolaeth, a glynu at y rhain yn gyson.
- **Dim Ysmygu:** Er mwyn rhoi'r cyfle gorau i'r holl gleifion, ymwelwyr a staff fod yn iach, mae pob un o safleoedd y Bwrdd Iechyd/Ymddiriedolaeth, gan gynnwys yr adeiladau a'r tiroedd, yn ddi-fwg.
- **Datganiad Hyblygrwydd:** Amlinellir dyletswyddau'r swydd yn y Swydd-ddisgrifiad a Manyleb y Person hyn, ac mae'n bosibl y caiff y rhain eu newid gyda chytundeb y naill a'r llall o bryd i'w gilydd.

Teitl y swydd:

